



PG-EG SANITARY FILTER HOUSINGS

Process Filtration

Stainless steel gas filter housings for sanitary applications.

Donaldson® PG-EG sanitary gas filter housings are designed for purification of compressed air and technical gases in the pharmaceutical, biotechnology, chemical, electronic, and food and beverage industries. PG-EG single round filter housings are equipped with sanitary Tri-Clamp®* connections and have an electropolished surface finish of Ra 32. The top vent is sealed with a pharma plug, while the bottom condensate drain is equipped with a pharma valve. (PG-EG filter housings are designed to yield low differential pressures at high flow rates.) Our multi-round housings are nitric passivated to Ra 32. They come standard with ANSI flange connections.

PG-EG sanitary filter housings are available in 12 different sizes with gas capacity ranging from 36 to 12,672 scfm at 100 psig, and steam capacity ranging from 100-17,100 lbs/hr at 50 psig. Optional connections are also available to adapt the filter to meet your specific requirements. Standard housings utilize Donaldson filter elements with 2-inch, double O-Ring, plug-in connections. A broad selection of filter elements is available to meet the compatibility and micron rating requirements of your process.



PG-EG

SPECIFICATIONS

MATERIALS

Filter Housing	316L SS
Clamp	304 SS
Pharma Plug (if applicable)	316 SS
Pharma Valve (if applicable)	316 SS
Housing Gasket	EPDM

DESIGN PRESSURE AND TEMPERATURE

Tri-Clamp Housings	232 psig @ 392°F
ANSI Flange Housings	150 psig @ 450°F

3-A SANITARY CERTIFIED

Models 0006-0192	3-A stamped
------------------	-------------

*Tri-Clamp is a registered trademark of Ladish Company.

SURFACE FINISH – INNER/OUTER

PG-EG 0006-0192	Electropolished to Ra 32
PG-EG 0432-1920	Nitric passivated to Ra 32

CONNECTIONS	VENT	DRAIN
PG-EG 0006-0192	DN 20 Tri-Clamp with 1/8" BSP Pharma Plug	1/8" BSP Pharma Valve
PG-EG 0032-0192	1 1/2" Tri-Clamp with 1/4" BSP plug	1/4" BSP Pharma Valve
PG-EG 0432-1920	1/2" Tri-Clamp with cap for vent and drain	

CONNECTION TYPES

Tri-Clamp (up to PG-EG 0192)
ANSI Flange (PG-EG 0432 and up)
Welded End (optional)

Other connections and larger housings are available on request.

DIMENSIONS

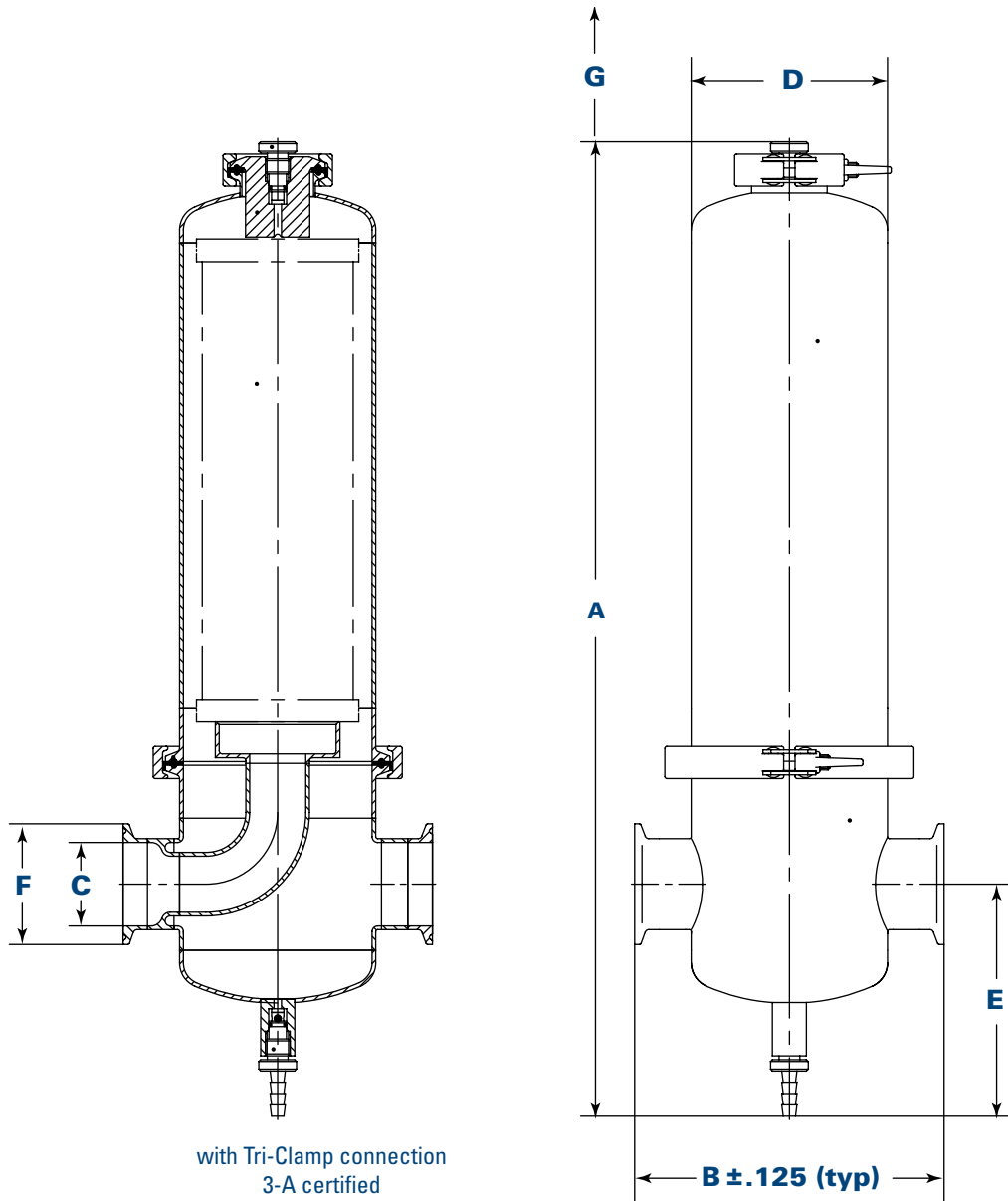

Size	Volume (gal)	Weight* (lbs)	Dimensions (inches)							Qty & Element Size
			A	B	øC	øD	E	øF	G	
0006	0.16	3.3	11.40	4.72	0.50	2.76	3.76	1.00	5.9	1 x 03/10
0018	0.21	3.8	13.50	4.72	0.50	2.76	3.76	1.00	8.0	1 x 05/20
0032	0.50	5.0	16.20	6.40	1.00	4.10	4.84	2.00	9.0	1 x 05/30
0072	0.90	6.5	21.20	6.50	2.00	4.10	4.84	2.52	14.2	1 x 10/30
0144	1.43	10.0	32.40	8.14	2.50	4.10	5.43	2.96	24.0	1 x 20/30
0192	1.95	12.5	41.00	8.14	3.00	4.10	5.43	3.60	33.9	1 x 30/30

* Without filter element

CLAMP CONNECTION

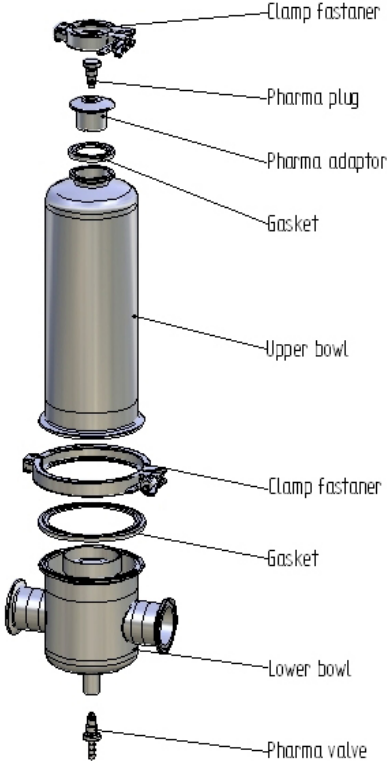
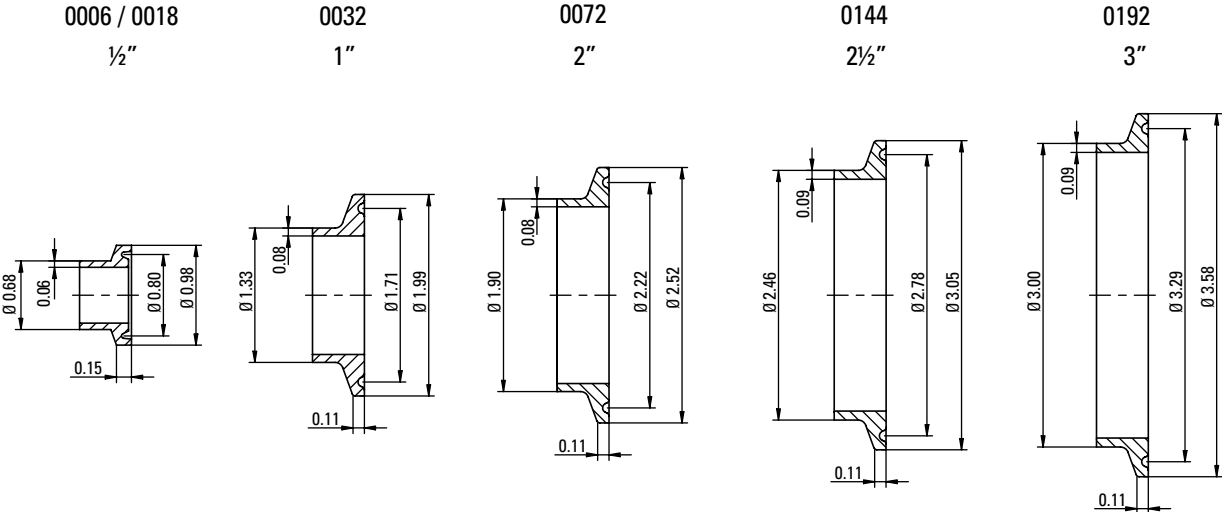

* PF-EG & PG-EG single filter element housings meet 3-A Sanitary Standards.

DIMENSIONS

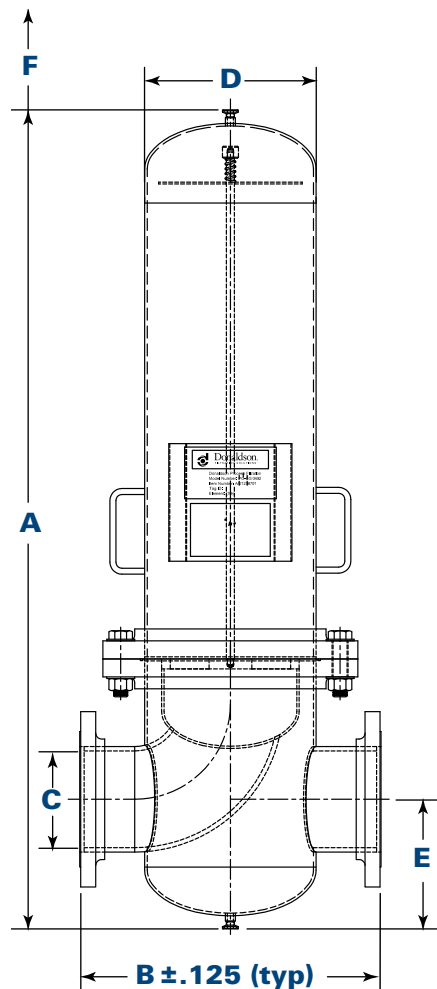

with ANSI Flange connection
ASME Code Stamped

Size	Weight* (lbs)	Dimensions (inches)						Qty & Element Size
		A	B	C**	D	E	F	
0432	140	38.0	16.14	4	8.6	7.3	23	3 x 20/30
0576	183	48.8	16.14	4	8.6	7.3	33	3 x 30/30
0768	292	51.5	18.90	6	10.8	8.1	33	4 x 30/30
1152	360	55.7	21.26	6	12.8	9.3	33	6 x 30/30
1536	616	59.5	26.00	8	16.0	12.8	33	8 x 30/30
1920	616	59.7	26.00	8	16.0	12.8	33	10 x 30/30

* Without filter element
** 150 lb, ANSI B 16.5

Important Notice

Many factors beyond the control of Donaldson can affect the use and performance of Donaldson products in a particular application, including the conditions under which the product is used. Since these factors are uniquely within the user's knowledge and control, it is essential the user evaluate the products to determine whether the product is fit for the particular purpose and suitable for the user's application. All products, specifications, availability and data are subject to change without notice, and may vary by region or country.



Donaldson Company, Inc.
Process Filtration
PO Box 1299
Minneapolis, MN
55440-1299 U.S.A.

Tel 800-543-3634 (USA)
Tel 800-343-3639 (within Mexico)
Fax 952-885-4791
processfilters@donaldson.com
donaldsonprocessfilters.com



PG-EG Sanitary Filter Housings (01/17)

© 2009 Donaldson Co., Inc. All Rights Reserved. Donaldson and the color blue are marks of Donaldson Company, Inc. All other marks belong to their respective owners. (Contains Donaldson proprietary technology.)